

STIHL[®]

Chain Saw Safety Manual

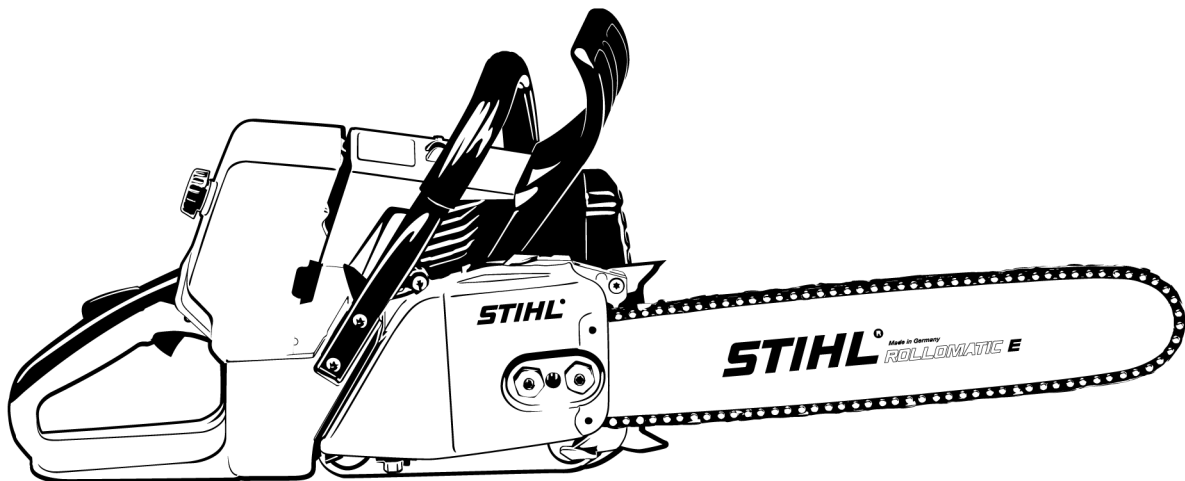

Contents

Safety Precautions and Working Techniques	2
Maintenance and Care	14
Main Parts	16

This manual contains the safety precautions and recommended cutting techniques outlined in the instruction manuals for STIHL chain saws.

The chapter on "Main Parts of the Saw" shows the MS 211 as an example. Other chain saw models may have different parts and controls.

This manual contains references to various chapters in the model-specific instruction manuals.

You should therefore always refer to the instruction manual of your particular saw model.

Please contact your STIHL dealer if you any questions after reading this manual.



Safety Precautions and Working Techniques



Special safety precautions must be observed when using a chain saw because the work goes faster than with an axe and a hand saw, because the chain runs at very high speeds, and because the cutters are extremely sharp.



It is important that you carefully read the entire Instruction Manual before using the machine for the first time and keep it in a safe place for future reference. Non-compliance with the Instruction Manual may cause serious or even fatal injury.

Observe the national safety regulations issued, for example, by the employers' liability insurance association, social security institutions, occupational safety and health authorities or other organizations.

If you have never used a power tool before: Ask the salesperson or another expert to explain how to use it safely – or attend a training course.

Minors should never be allowed to use a chain saw – except for young trainees over the age of 16 when working under supervision.

Keep children, animals and bystanders well away from the machine.

When not using the machine, it must be laid down in such a way that it does not endanger anyone. Ensure that the machine cannot be used without authorization.

The user is responsible for accidents or risks involving third parties or their property.

The machine should only be provided or loaned to people familiar with this model and its operation – and the Instruction Manual should always be handed over with the machine.

The machine may only be operated by people who are fit, in good physical health and in good mental condition. If you have any condition that might be aggravated by strenuous work, check with your doctor before operating a power tool.

If you have a pacemaker: The ignition system of your machine produces an electromagnetic field of very low intensity. An effect on individual pacemaker types cannot be excluded entirely. STIHL recommends that you consult your doctor and the manufacturer of your pacemaker in order to avoid all health hazards.

Anyone who has consumed alcohol, medicines affecting their ability to react or drugs must not operate a power tool.

Postpone the work if the weather is bad (rain, snow, ice, wind) - **higher risk of accidents!**

Do not cut any material other than wood or wooden objects.

Other uses are not permitted and may lead to accidents or damage to the machine. The machine must not be modified in any way - this may also lead to accidents or damage to the machine.

Only use tools, guide bars, chains, chain sprockets or accessories that have been approved by STIHL for this machine or which are technically equivalent. Contact a dealer if in doubt. Only use high-quality tools or accessories. Otherwise there may be a risk of accidents or damage to the machine.

STIHL recommends the use of genuine STIHL tools, guide bars, chains, chain sprockets and accessories. These have been optimized for the product and the user's requirements.

Clothing and equipment

Wear proper protective clothing and equipment.



Clothing must be sturdy and snug-fitting, but allow complete freedom of movement. Wear snug fitting clothing with **cut-retardant pads** – an overall, not a loose-fitting jacket.

Clothing which could become trapped in wood, brush or moving parts of the machine should not be worn. Do not wear a scarf, tie or jewelry when operating the machine. Long hair must be tied up and covered (headscarf, cap, helmet, etc.).



Wear **safety boots** – with cut-retardant material, non-slip soles and steel toe caps



Wear a **hard hat** – if objects could fall on you.

Wear **safety glasses** or a **face shield** and "personal" **hearing protection** – e.g., ear defenders.



Wear **heavy-duty, non-slip gloves** – preferably made of leather.

STIHL can supply a comprehensive range of protective clothing and equipment.

Transporting the chain saw

Always engage the chain brake and attach the chain scabbard – even before transporting the saw for short distances. When transporting the saw for longer distances (more than approx. 50 m), also stop the engine.

Always carry the saw by the handlebar – with the hot muffler away from your body, the guide bar must point to the rear. Avoid touching hot parts of the machine, especially the surface of the muffler – **risk of burns!**

In vehicles: When transporting in a vehicle, properly secure your machine to prevent turnover, damage and fuel spillage.

Refueling



Gasoline is an extremely flammable fuel – keep clear of naked flames and fire – do not spill any fuel – no smoking.

Switch off the engine before refueling.

Never refuel the machine while the engine is still hot – the fuel may spill over – **risk of fire!**

Open the filler cap carefully so that any excess pressure is relieved gradually and fuel does not splash out.

The machine may only be refueled in a well ventilated place. Clean the machine immediately if fuel is spilled. Change your clothes immediately if they are contaminated with fuel.

A number of different filler caps are installed as standard at the factory.

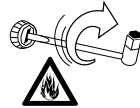

Close the filler cap as tightly as possible after refueling.



Place the cliplock filler cap (bayonet-type) in position, turn it until it will go no further and fold the cliplock down.

This helps reduce the risk of unit vibrations causing an incorrectly tightened filler cap to loosen or come off and spill quantities of fuel.

Before starting

Check that saw is properly assembled and in good condition - refer to appropriate chapters in the Instruction Manual:

- functional chain brake, front hand guard
- Correctly mounted guide bar
- Correctly tensioned chain
- The throttle trigger and throttle trigger interlock must move easily – throttle trigger must return automatically to the idle position when released.
- Master control/stop switch must move easily to **STOP** or **0**
- Check that the spark plug boot is secure. A loose boot can lead to flying sparks which may ignite the escaping fuel/air mixture – **risk of fire!**
- Never attempt to modify the controls or safety devices
- Keep the handles dry and clean – free from oil and pitch – for safe control of the chain saw.

The chain saw should only be used if it is in full working order – **risk of accident!**

Starting the engine

Move at least 3 meters away from the place at which the machine was refueled and never in enclosed spaces.

The machine is operated by only one person – there should not be any other person within the working area – not even when starting the machine.

Lock the chain with the chain brake before starting – risk of **personal injury** due to rotating chain!

Do not drop-start the engine – start as described in the Instruction Manual.

Do not start the chain saw if the chain is in a cut.

During work

In the event of impending danger or in an emergency, switch off the engine immediately by moving the Master Control/stop switch to **STOP** or **0**.

Never let the machine run unattended.

When the engine is running: Note that the chain continues to rotate for a short period after your let go of the throttle trigger – coasting effect.

Exercise caution with slippery surfaces, water, snow, ice, steep slopes, uneven ground or green wood that has just been stripped of its bark –**danger of slipping!**

Use caution with tree stumps, roots, ditches – **danger of stumbling!**

Ensure you always have a firm and safe footing.

Do not work alone – keep within calling distance of others in case help is needed.

More care and attention than usual are required when wearing ear protection, since warning sounds (shouts, alarms, etc.) cannot be heard properly.

Take breaks in due time in order to prevent tiredness and exhaustion – **risk of accidents!**

Keep easily combustible materials (e.g., wood chips, bark, dry grass, fuel) away from hot exhaust gases and hot mufflers – **risk of fire!** Mufflers with catalytic converters can become especially hot.



Your power tool produces toxic exhaust fumes as soon as the engine is running. These gases may be colorless and odourless and may contain unburnt hydrocarbons and benzene. Never run the engine indoors or in poorly ventilated areas, even if your model is equipped with a catalytic converter.

Ensure proper ventilation when working in trenches, hollows or other confined areas. **Toxic fumes can kill!**

If you feel sick, if you have a headache, vision problems (e.g., your field of vision gets smaller), hearing problems, dizziness or inability to concentrate, stop work immediately. Such symptoms may be caused by an excessively high concentration of exhaust emissions – **risk of accident!**

Dust (e.g., sawdust), fumes and smoke produced while using the machine may be hazardous to health. Wear a dust mask if dust is generated.

No smoking when working with or near the machine - **risk of fire!** Combustible fuel vapor may escape from the fuel system.

If the machine is subjected to unusually high loads for which it was not designed (e.g., heavy impact or a fall), always check that it is in good condition before continuing work - refer also to the section "Before starting". Check the fuel system for leaks and make sure the safety devices are working properly. Never continue using a power tool that is not in perfect working order. Consult a STIHL dealer if in doubt.

Make certain that the saw chain does not continue rotating when the engine is idling – if necessary, correct the low speed setting – if the chain continues to keep rotating in idle, have it checked by a servicing dealer.

Reactive forces

The most common reactive forces are: kickback, pushback and pull-in.

Dangers of kickback



Kickback can result in fatal cuts.

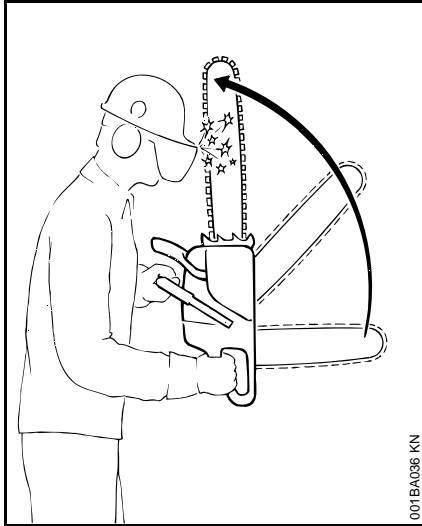

Kickback occurs when the saw is suddenly thrown up and back in an uncontrolled arc towards the operator.

Kickback occurs if, for example,

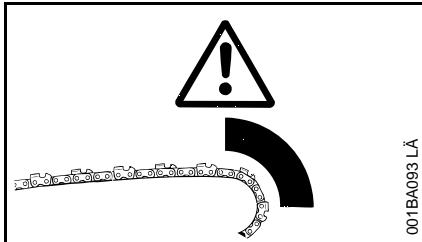

- the saw chain in the area of the upper quarter of the guide bar nose unintentionally comes into contact with wood or a solid object – e.g., unintentionally touches another limb during limbing
- the saw chain at the nose of the guide bar is pinched in the cut

Quickstop chain brake:

This device reduces the risk of injury in certain situations - it cannot prevent kickback. When activated, the chain brake stops the saw chain within a fraction of a second – for a description of this device refer to the section "Chain Brake" in this Instruction Manual

Reduce the risk of kickback

- Work cautiously and methodically
- Hold the chainsaw firmly with both hands and maintain a secure grip.
- Always cut at full throttle
- Be aware of the location of the guide bar nose
- Do not cut with the guide bar nose
- Be especially careful with small, tough limbs, undergrowth and offshoots – the saw chain may become caught in them
- Never cut several limbs at once
- Do not lean too far forward
- Do not cut above shoulder height
- Use extreme caution when re-entering a previous cut.
- Do not attempt plunge cuts if you are not experienced in this cutting technique
- Be alert for shifting of the log or other forces that may cause the cut to close and pinch the chain

- Always cut with a correctly sharpened, properly tensioned saw chain - the depth gauge setting must not be too large.
- Use low-kickback saw chains as well as narrow-radius guide bars

Pull-in (A)

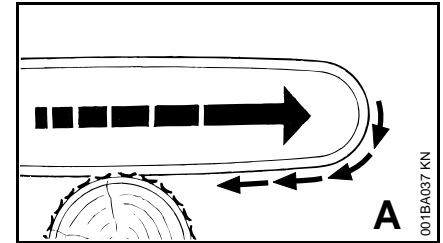

When the chain on the bottom of the bar – overbucking – is suddenly pinched, caught or encounters a foreign object in the wood, the chain saw may suddenly be drawn forward toward the log – **to avoid this, engage the bumper spike firmly in the wood.**

Pushback (B)

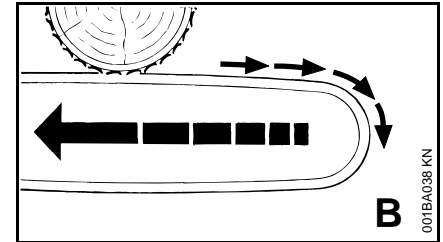

When the chain on the top of the bar – underbucking – is suddenly pinched, caught or encounters a foreign object in the wood, the chain saw may suddenly be driven straight back toward the operator – **to avoid this:**

- Do not allow the top of the guide bar to become jammed
- Do not twist the guide bar in the cut

Be very careful

- with freely hanging limbs
- with trunks that are under tension between other trees because they fell unfavorably
- when working in windbreaks

In these cases, do not use a chain saw – use a hoist, winch or dragline instead.

Pull out trunks that are lying about and have been cut free. Whenever possible, deal with them in open areas.

Deadwood (brittle, rotten or dead wood) poses a substantial, highly unpredictable hazard. It is extremely difficult or even practically impossible to recognize the danger. Use aids such as winches or draglines.

Always be especially careful when **felling timber near roads, railway lines, power lines** etc. If necessary, notify police, power companies or railway authorities.

Holding and guiding the machine

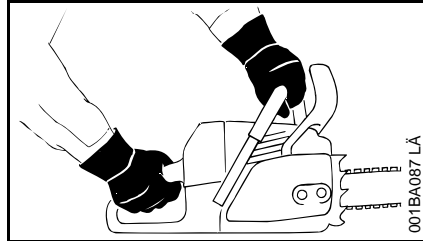

Always hold the chain saw **firmly with both hands**: Right hand on the rear handle – even if you are left-handed. To ensure reliable control, wrap your thumbs tightly around the handlebar and handle.

Sawing

Do not use the starting throttle position for cutting. Engine speed cannot be controlled with the throttle trigger in this position.

Work calmly and methodically – only with good lighting and visibility. Do not endanger others – stay alert at all times.

Use the shortest possible guide bar: The chain, guide bar and chain sprocket must match each other and your saw.

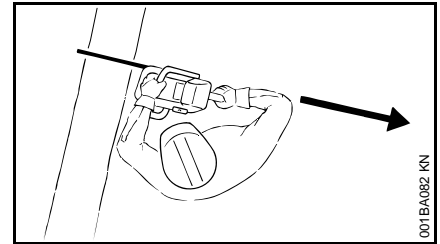

Make certain that all parts of your body are well clear of the extended **range of travel** of the saw chain.

Always pull the saw out of the cut with the saw chain running.

Use the chain saw only for sawing – not for prying or shoveling away limbs or roots.

Do not underbuck freely hanging limbs.

Be careful when cutting shattered wood – **risk of injury from splinters being caught and thrown in your direction!**

Make sure your saw does not touch any foreign materials: Stones, nails, etc. may be flung off and damage the saw chain – the saw may kick back unexpectedly.

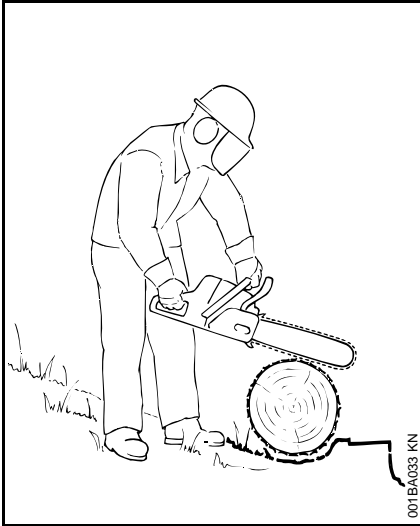

On slopes, always stand above or to the side of the trunk or felled tree. Watch out for rolling trunks.

When working above ground level:

- always use a lift bucket
- never work on a ladder
- not in a tree
- not in unsteady locations
- not above shoulder height
- not with one hand

Begin cutting with the saw at full throttle and engage the bumper spike – then saw.

Never use the chain saw without the bumper spike, the saw may pull you forward suddenly. Always engage the bumper spike securely.

At the end of the cut, the chain saw is no longer supported by the cutting attachment in the cut. The machine's weight must be borne by the user – **risk of loss of control!**

Felling

Felling may only be carried by persons who have had special training. Persons who are not experienced chain saw users should carry out neither felling nor limbing – **increased risk of accidents!**

Comply with national regulations regarding felling technique.

Only persons who are engaged in felling may be present in the felling area.

Make certain that no one is endangered by the falling tree – engine noise can drown out shouting.

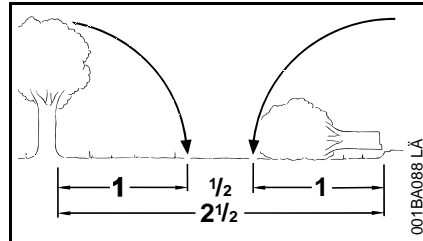

The distance to the next worksite must be at least 2 1/2 tree lengths

Determine direction of fall and escape paths

Select a gap in the timber stand into which the tree can be felled.

Pay special attention to the following points:

- the natural inclination of the tree
- unusually heavy limb structure, asymmetrical growth, damage to tree
- wind direction and speed – do not fell trees in high winds
- direction of slope
- neighboring trees
- snow load
- Take the general condition of the tree into account – be especially careful with trunk damage or deadwood (brittle, rotten or dead wood)

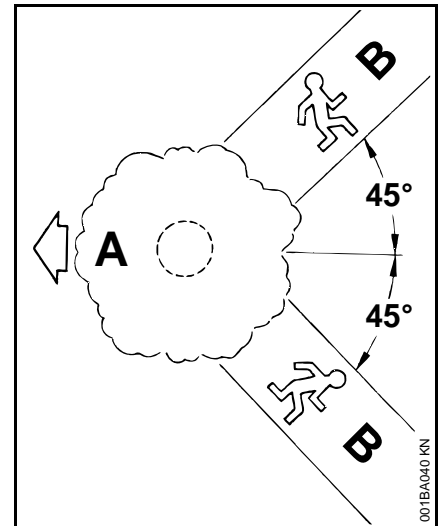

A direction of fall

B escape paths

English

- Establish escape paths for each worker – approx. 45° diagonally backwards
- Clear escape paths, eliminate obstacles
- Put down tools and equipment at a safe distance – but not on the escape paths
- When felling, stand only to the side of the falling trunk and only move back laterally onto the escape route
- Plan escape routes on slopes parallel to the slope
- When getting out of the way, watch out for falling branches and the crown area

Preparing the work area at the trunk

- Clear the work area at the trunk of branches, brush and other obstacles – secure footing for all workers
- Carefully clear the base of the trunk (e.g., with an axe) – sand, stones and other foreign objects will dull the saw chain

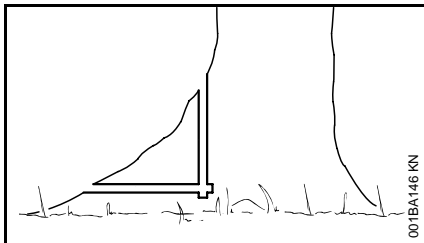

- Remove large buttresses: remove the largest buttress first – saw first vertically, then horizontally – only if the tree is in sound condition

Making a felling notch

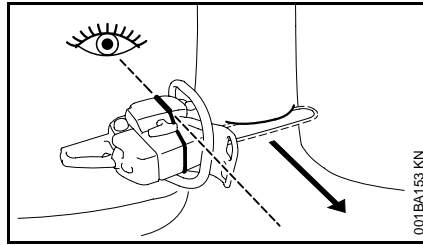

With the help of the gunning sight on the shroud and fan housing of the chain saw, it is possible to check the direction of fall when cutting the felling notch.

When making the felling notch, orient the chain saw so that the gunning sight points precisely in the direction in which you want the tree to fall.

Several possibilities are permissible when it comes to the sequence of horizontal and diagonal cuts – observe national regulations with regard to felling technique.

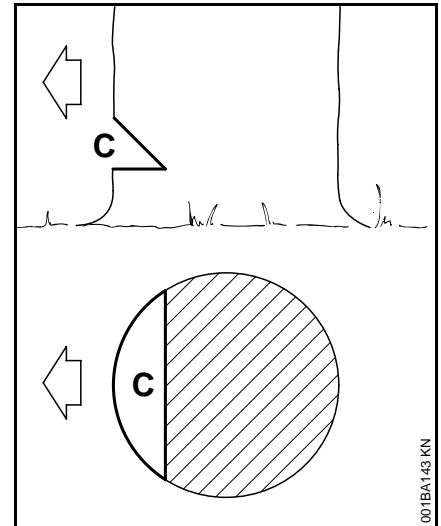

The felling notch (C) determines the direction of fall.

STIHL recommends the following procedure:

- Make a horizontal cut – in doing so, check the direction of fall with the gunning sight
- Start a diagonal cut at an approx. 45° angle
- Check the felling notch – then correct the felling notch, if necessary

Important:

- Felling notch at right angle to direction of fall
- As close to the ground as possible
- cut to a depth of approx. 1/5 to 1/3 of the diameter of the trunk

Sapwood cuts

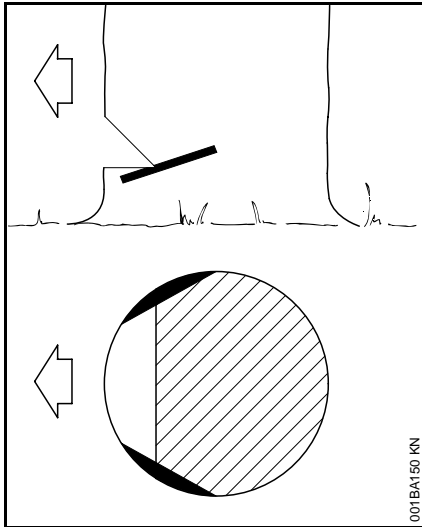

With long-fibered wood, sapwood cuts prevent the sapwood from splintering when felling the trunk – saw both sides of the trunk at the level of the felling notch base to approx. 1/10 of the diameter of the trunk – with thicker trunks, not more than the width of the guide bar.

Do not use sapwood cuts on diseased trees.

Felling cut

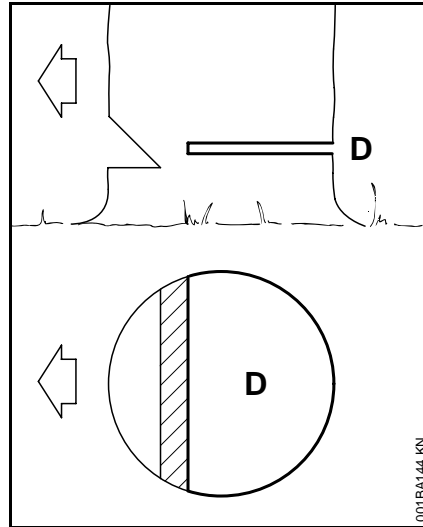

Give a warning cry of "timber!" before making the felling cut.

- Make the felling cut (D) slightly higher than the horizontal cut of the felling notch
- Exactly horizontal
- approx. 1/10 of the diameter of the trunk must remain standing between the felling cut and the notch = bridge

Insert wedges in the felling cut in time – use only wedges made of wood, light metal or plastic - no steel wedges. Steel wedges damage the saw chain and can cause kickback.

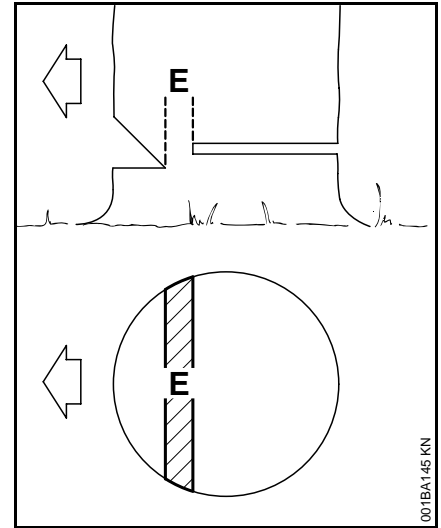

The **bridge** (E) functions as a hinge to guide the tree to the ground.

- Never saw through the bridge while felling – otherwise the tree will fall in a direction other than the one planned – **risk of accident!**
- With rotten trunks, leave a wider bridge

Immediately before felling the tree, give out a second warning cry of "timber!".

Thin trunks: simple fan cut

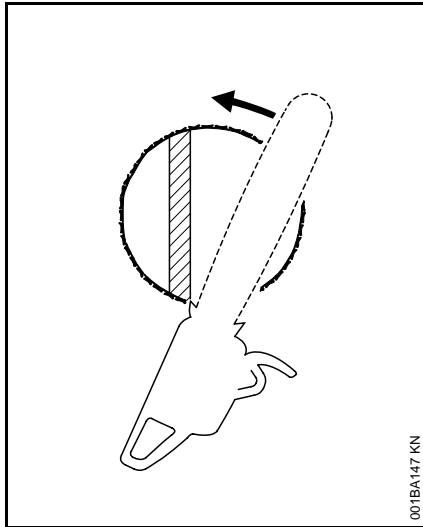

- Engage the spiked bumper behind the hinge. Pivot the chain saw around this point – only as far as the bridge – the spiked bumper rolls against the trunk.

Large diameter trunks: sectioning method

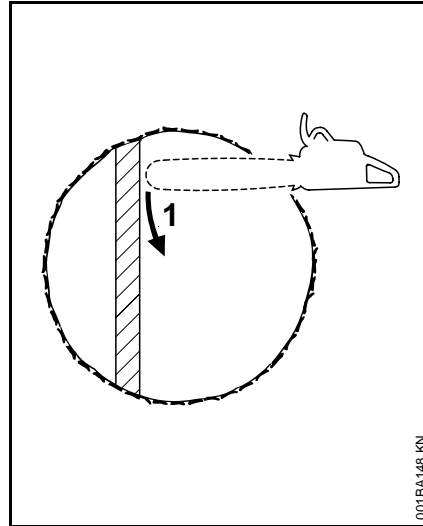

Use the sectioning method if the diameter of the trunk exceeds the length of the chain saw guide bar.

1. First cut

The nose of the guide bar should enter the wood just behind the hinge – hold the saw absolutely horizontally and swing it as far as possible – use the spiked bumper as a pivot point – reposition the chain saw as little as possible.

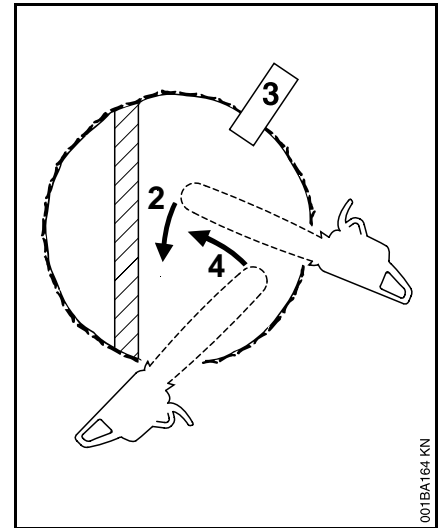

2. While repositioning for the next cut, keep the guide bar fully engaged in the cut in order to avoid an uneven felling cut - apply the spiked bumper again, etc..
3. Insert wedge (3)
4. Last cut: Position the chain saw as for the simple fan cut – do not saw through the hinge!

Special cutting techniques

Plunge-cutting and heartwood cutting require training and experience.

Plunge-cutting

- for felling leaners
- for relieving cuts during bucking
- for DIY projects

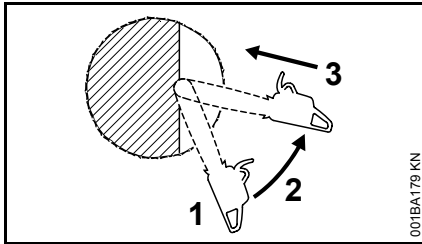

- use a low kickback chain and be especially cautious
1. Begin the cut by applying the lower portion of the guide bar nose – do not use the upper portion – **risk of kickback!** Cut until the depth of the kerf is twice the width of the guide bar
 2. Swing the saw slowly into the plunge-cutting position – **risk of kickback or pushback!**
 3. Make the plunge cut very carefully – **danger of pushback!**

Heartwood cut

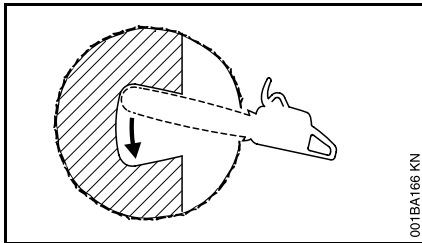

- if the diameter of the trunk exceeds twice the length of the guide bar
- if a piece of heartwood remains uncut on large diameter trunks

- with trees that are difficult to fell (oak, beech), to make possible to maintain the planned direction of fall more precisely and prevent the heartwood from splintering
 - with soft deciduous trees to relieve tension in horizontal trunks and prevent splinters of wood from being torn out of the trunk
- Make the plunge cut in the felling notch very carefully – **danger of pushback!** – then swing in the direction of the arrow

Limbing

Limbing may only be carried by persons who have had special training. Persons who are not experienced chain saw users should carry out neither felling nor limbing – **risk of accidents!**

- use a low-kickback saw chain
- Support the chain saw as much as possible
- Do not stand on the trunk when limbing
- Do not cut with the guide bar nose
- Watch out for limbs that are under tension
- Never cut several limbs at once

Sawing thin wood

- Use a sturdy, stable fixture – sawhorse
- Do not hold the wood in place with your foot
- Other persons must neither be allowed to hold the wood nor help in any other way

Lying or standing logs under tension

Always make the cuts in the correct order (first compression side (1), then tension side (2), otherwise the chain saw may pinch or kick back – **risk of injury!**)

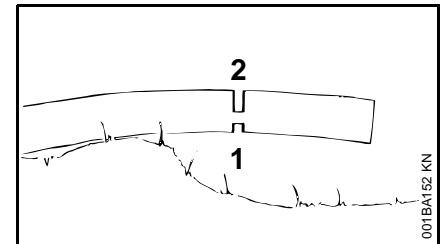
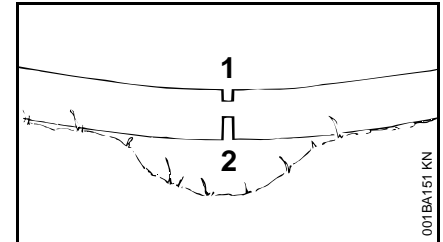

- Make relieving cut in the compression side (1)
- Make bucking cut in the tension side (2)

If the bucking cut is made from the bottom upwards (underbuck) – **risk of pushback!**



Lying logs must not touch the ground at the point where the cut is made – otherwise the chain will be damaged.

Ripping

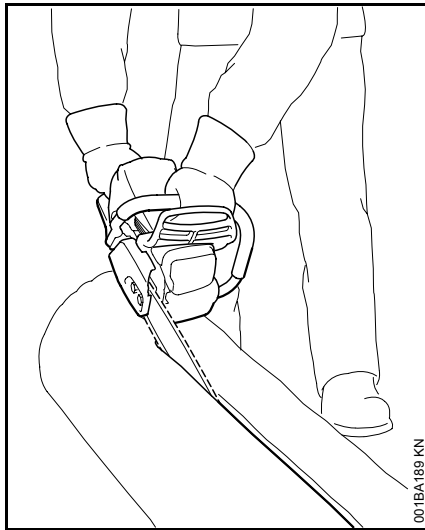

Sawing technique without use of the spiked bumper – risk of pull-in – position the guidebar at as shallow an angle as possible – be especially careful – increased **risk of kickback!**

Vibrations

Prolonged use of the power tool may result in vibration-induced circulation problems in the hands ("white finger disease").

No general recommendation can be given for the length of usage because it depends on several factors.

The period of usage is prolonged by:

- Hand protection (wearing warm gloves)
- Work breaks

The period of usage is shortened by:

- Any personal tendency to suffer from poor circulation (symptoms: frequently cold fingers, tingling sensation)
- Low outside temperatures
- Amount of gripping force (holding the power tool tightly restricts circulation)

Users who use the machine periodically or for long periods or users who repeatedly experience corresponding symptoms (e.g., tingling sensation in fingers), should undergo a medical examination.

Maintenance and repairs

The machine must be serviced regularly. Do not attempt any maintenance or repair work not described in the Instruction Manual. All other work should be carried out by a servicing dealer.

STIHL recommends that maintenance and repair work be carried out only by authorized STIHL dealers. STIHL dealers receive regular training and are supplied with technical information.

Use only high-quality replacement parts, in order to avoid the risk of accidents or damage to the machine. Contact a dealer if in doubt.

STIHL recommends the use of genuine STIHL spare parts. Such parts have been optimized for the machine and the user's requirements.

Before starting any maintenance or repair work and before cleaning the machine, always **stop the engine and disconnect the spark plug boot – risk of injury** if the engine starts up inadvertently! – Exception: adjustment of carburetor and idle speed.

To reduce the **risk of fire** due to ignition outside the cylinder, move the slide control / stop switch to **STOP** or **0** before turning the engine over on the starter with the spark plug boot removed or the spark plug unscrewed.

Do not service or store the machine near a naked light - **risk of fire** due to the fuel.

Check fuel cap regularly for tightness.

Use only spark plugs that are in perfect condition and have been approved by STIHL – see Specifications.

Inspect ignition lead (insulation in good condition, secure connection).

Check that the muffler is in perfect working condition.

Do not use the machine if the muffler is damaged or missing – **risk of fire!** – **Hearing damage!**

Never touch a hot muffler – **risk of burns!**

The condition of the antivibration elements influences vibration behavior – inspect antivibration elements periodically.

Inspect chain catcher – replace if damaged.

Switch off engine

- to check the chain tension
- to retension the chain
- to change chains
- for remedying malfunctions

Observe sharpening instructions – for safe and proper handling, always keep the chain and guide bar in flawless condition. Keep the chain properly sharpened, tensioned and well lubricated.

Change chain, guide bar and chain sprocket in due time.

Check that the clutch drum is in perfect working condition.

Always store fuel and chain lubricant only in the specified type of containers and ensure they are correctly labeled. Avoid direct skin contact with gasoline. Do not inhale gasoline vapors – **danger to health!**

In the event of a chain brake malfunction, switch off the machine immediately – **risk of injury!** Consult a dealer – do not use the machine until the malfunction has been remedied, see "chain brake".

Maintenance and Care

The following maintenance intervals apply for normal operating conditions only. If your daily working time is longer or operating conditions are difficult (very dusty work area, resin-rich wood, tropical wood, etc.), shorten the specified intervals accordingly. If you only use the saw occasionally, extend the intervals accordingly.		before starting work	after finishing work or daily	after each refueling stop	weekly	monthly	every 12 months	if problem	if damaged	if required
Complete machine	Visual inspection (condition, leaks)	X		X						
	Clean		X							
Throttle trigger, trigger interlock, choke lever, stop switch, Master Control lever (depending on version)	Check operation	X		X						
Chain brake	Check operation	X		X						
	Have checked by dealer ¹⁾									X
Pickup body/filter in fuel tank	Check					X				
	Clean, replace filter element					X		X		
	Replace						X		X	X
Fuel tank	Clean					X				
Chain oil tank	Clean					X				
Chain Lubrication	Check	X								
Saw chain	Inspect, also check sharpness	X		X						
	Check chain tension	X		X						
	Sharpen									X
Guide bar	Check (wear, damage)	X								
	Clean and turn over									X
	Deburr				X					
	Replace								X	X
Chain sprocket	Check				X					
Air filter	Clean							X		X
	Replace								X	
Anti-vibration elements	Check	X						X		
	Have replaced by dealer ¹⁾								X	

The following maintenance intervals apply for normal operating conditions only. If your daily working time is longer or operating conditions are difficult (very dusty work area, resin-rich wood, tropical wood, etc.), shorten the specified intervals accordingly. If you only use the saw occasionally, extend the intervals accordingly.		before starting work	after finishing work or daily	after each refueling stop	weekly	monthly	every 12 months	if problem	if damaged	if required
Cooling inlets	Clean		X							
Cylinder fins	Clean		X			X				
Carburetor	Check idle adjustment – chain must not rotate	X		X						
	Adjusting Idle Speed									X
Spark plug	Readjust electrode gap							X		
	Replace after 100 hours of operation									
All accessible screws and nuts (not adjusting screws) ²⁾	Retighten									X
Spark arresting screen in muffler (not all markets)	Check ¹⁾							X		
	Clean, replace if necessary ¹⁾								X	
Chain catcher	Check	X								
	Replace								X	
Safety labels	Replace								X	

1) STIHL recommends a STIHL servicing dealer.

2) Firmly tighten down the cylinder base screws of professional saws (3.4 kW or more) after 10 to 20 hours of operation.

Main Parts

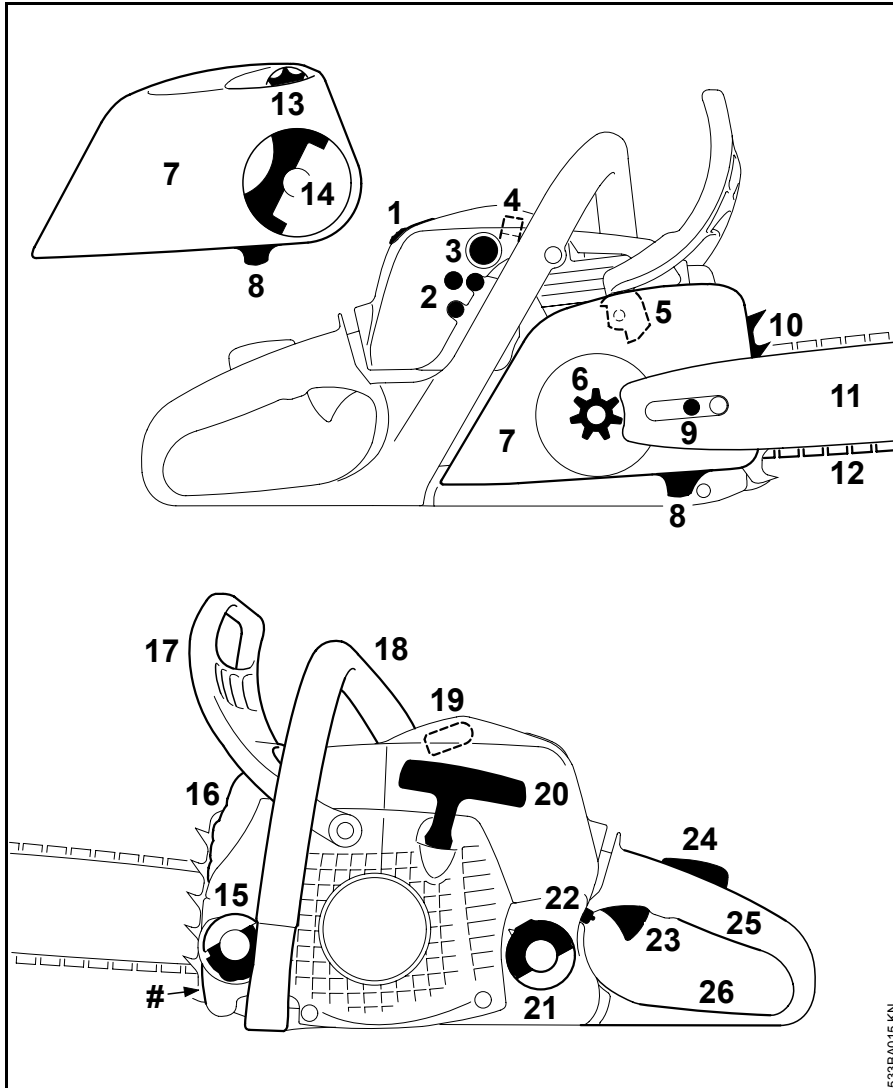

- 1 Shroud lock
- 2 Carburetor adjusting screws
- 3 Fuel pump (easy start¹⁾)
- 4 Shutter (summer / winter operation, MS 211 only)
- 5 Chain brake
- 6 Chain sprocket
- 7 Chain sprocket cover
- 8 Chain catcher
- 9 Chain tensioner (side)
- 10 Bumper spike
- 11 Guide bar
- 12 Oilmatic saw chain
- 13 Adjusting wheel (quick chain tensioner)
- 14 Handle of wingnut¹⁾ (quick chain tensioner)
- 15 Oil filler cap
- 16 Muffler
- 17 Front hand guard
- 18 Front handle (handlebar)
- 19 Spark plug boot
- 20 Starter grip
- 21 Fuel filler cap
- 22 Master Control lever
- 23 Throttle trigger
- 24 Throttle trigger interlock
- 25 Rear handle
- 26 Rear hand guard
- # Serial number

1) Depending on model

0457-184-0121

englisch



www.stihl.com



0457-184-0121